

AFT Arrow™ 8

Compressible Pipe Flow Analysis
& System Modeling Software

Dynamic solutions for a fluid world™



Evaluate New Designs and Improve Your Installed Systems

AFT Arrow is a fluid dynamic simulation software used to calculate flow distribution and pressure drop in gas piping and ducting systems.

Designed for compressible flow systems containing steam, compressed air, chemical and petrochemical process gases, natural gas transport and more, AFT Arrow is an indispensable tool to help you tackle your most challenging systems.



Capabilities

- Experiment with operating conditions and scenarios
- Easily change system input data, including valve positions, compressor or fan operation, control set points, pressures, temperatures, and more
- Model a wide range of system components from handbook empirical sources, or input manufacturer data
- Simulate ideal or real gases
- Choose between isothermal, adiabatic or generalized heat transfer conditions
- Conduct flow analysis with high velocities including sonic choking
- Compile database libraries of frequently used components
- Assemble non-reacting mixtures and analyze dynamic mixtures resulting from intersecting flow streams
- Model rotating piping systems such as those found in steam and gas turbines
- Model effects of elevation changes such as in tall structures, subsurface mines and overland pipelines
- Evaluate codes and industry standards applied in the model

Benefits

- Understand the behavior of your system
- Predict how pipes, valves, compressors, fans and other components will interact with each other
- Evaluate the performance of new designs
- Assure all design requirements are met
- Identify and correct operational problems
- Produce less costly, more efficient and more reliable piping systems

Applications

- Pipe and duct sizing
- Relief valve sizing and system calculations
- Compressor and fan sizing and selection
- Control valve sizing and selection
- Simulate system operation and component interaction
- Calculate choked flow
- Evaluate pipe insulation and heat transfer in pipes and heat exchangers
- Troubleshoot existing systems to determine the cause of operational problems

Add-On Modules



Goal Seek & Control

Identifies input parameters that yield desired output values and simulates control functions



Automated Network Sizing

Automatically size your network to meet design requirements and minimize system cost

Features

- 2D flow diagram or isometric view interface
- Advanced solution methods provide highly accurate results
- Detailed modeling for fans and compressors, control valves, heat exchangers and other components
- Conduct compressor and fan energy cost analysis
- Thermal analysis including piping heat transfer and heat exchanger modeling
- Scenario Manager tracks all design variants and operational possibilities in a single model file
- Built-in libraries of fluids (including NIST REFPROP and ASME Steam Tables) and pipe fittings which can be extended and customized
- Chempak™ add-on utility provides a thermophysical database of almost 600 gases - allows you to define non-reacting pre-mixtures and simulate dynamic flow mixing

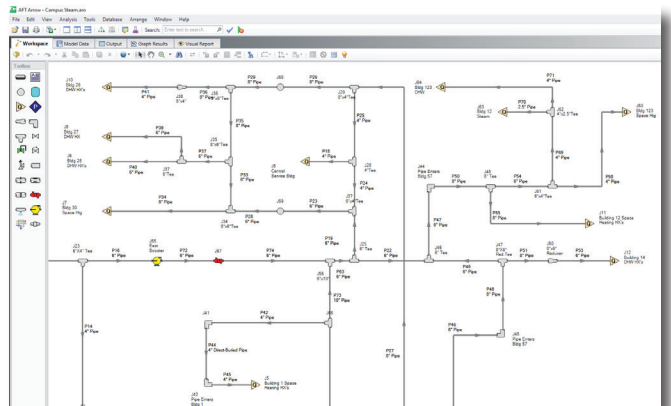
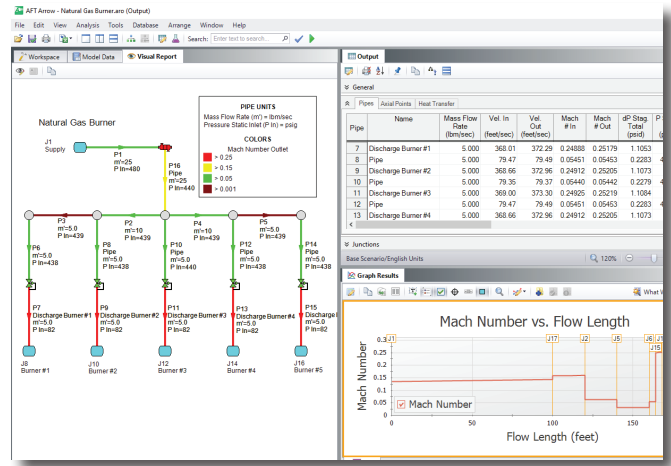

Data Integration

- Import piping layouts and dimensional data from GIS Shapefiles, CAESAR II® Neutral Files, and PCF files from a wide range of sources
- Robust Excel integration to import and export data

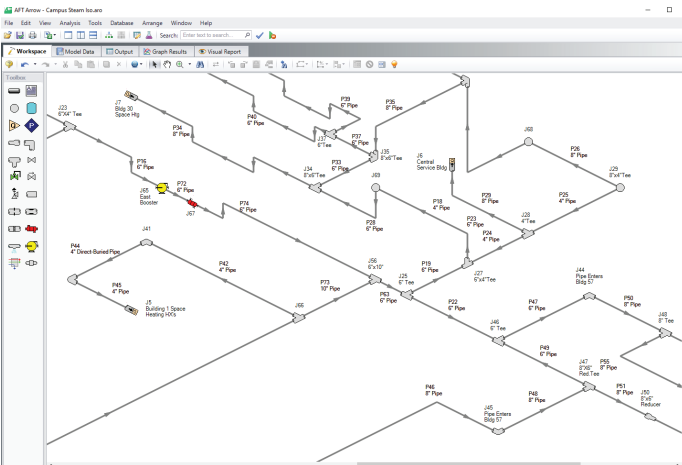

How does it work?

AFT Arrow's powerful solution engine simultaneously solves five fundamental equations; mass, momentum, energy, state and Mach number. It uses a modified Newton - Raphson matrix iteration method plus proprietary methods developed by AFT so you can achieve a true and rigorous compressible flow solution.

"AFT Arrow", "Applied Flow Technology", "Dynamic solutions for a fluid world" and the AFT logo are trademarks of Applied Flow Technology Corporation. "Chempak" is a trademark of Madison Technical Software Inc. CAESAR II is a third-party product owned and trademarked by an individual corporation.

World Class Support

Your software includes one free year of product upgrades and technical support. Additionally, AFT offers a variety of training for all levels of knowledge.



Training Seminars
This classroom style setting accelerates your skills and teaches you how to be an AFT analysis and simulation expert.



Free Webinars
Hosted webinars talk about products and solutions-based uses. Recorded webinars are located on our website.



Expert Assistance
Have more projects than you can handle or need expert analysis? Extend your team with our Flow Expert Package.



Tips & Tricks
Each month, an AFT engineer gives newsletter readers a new tip and trick to keep you up to date.